



BE WOOD & FAN

DESIGN
FRANCESCO RIFÉ

dynamobel



Be Wood

A balancing act between craftsmanship and precision Un acto de equilibrio entre artesanía y precisión Ein Balanceakt zwischen Handwerk und Präzision

Without losing sight of the brand's past, but seeking a new take on things, Dynamobel has come up with the Be Wood seating collection by Francesc Rifé. Exploring the ultimate possibilities of the range, a varied programme of chairs, all breathing the same air, has been created around the ideal of a wooden backrest and legs.

Using a sinuous, organic, contemporary language, the design intends to reinforce the new approaches to office space, maximising comfort in the environment and creating warm atmospheres. Also perfect for residential use and social settings, this Dynamobel programme is born of uniting the work of true craftsmen and a delicate industrial process, each piece refined to become the purest expression of the brand.

Be Wood comes with several backrest options and a range of seat widths and heights, its final identity depending on the choice of fabric and legs.

Con una mirada respetuosa hacia el pasado de la marca pero en busca de un nuevo enfoque, Dynamobel ha creado la colección de sillería Be Wood, diseñada por Francesc Rifé. La silla toma como punto de partida el respaldo y las patas en madera, y en torno a este ideal se ha erigido un amplio programa que respira el mismo aire y que pretende explorar las posibilidades de la gama.

Con un lenguaje contemporáneo, sinuoso y orgánico, el diseño ha sido creado para reforzar los nuevos planteamientos de oficinas, maximizando el confort en los espacios, y provocando ambientes cálidos. Perfecta también para el uso residencial y entornos sociales, este programa de Dynamobel nace de coordinar el trabajo de artesanos con un delicado proceso industrial, siendo cada pieza mimada hasta convertirse en la expresión más pura de la marca.

Be Wood se presenta en varias opciones de respaldo y diferentes anchuras y alturas de asiento, será en la elección de la tapicería y las patas donde se defina finalmente su identidad.

Mit einem respektvollen Blick in die Vergangenheit der Marke, aber auf der Suche nach einem neuen Ansatz hat Dynamobel zusammen mit dem Designer Francesc Rifé die Stuhlkollektion Be Wood geschaffen. Ausgangspunkt des Stuhls sind die Rückenlehne und die Holzbeine, und um diese herum wurde ein breites Programm entwickelt, das dieser Tendenz folgt und die Möglichkeiten der Produktreihe auszuschöpfen versucht.

Mit einer zeitgenössischen geschwungenen und organischen Ausdrucksweise entstand dieses Design, um die neuen Bürokonzepte zu unterstützen, mit dem Ziel, den Komfort in den Räumlichkeiten zu maximieren und warme Umgebungen zu schaffen. Ebenfalls eine perfekte Lösung für Wohnungen und soziale Umfelder entsteht dieses Programm von Dynamobel durch Koordinierung der Handwerksarbeit mit einem sensiblen Industrieprozess, wobei jedes Möbelstück bis zum reinsten Ausdruck der Marke kultiviert wird. Be Wood ist mit unterschiedlichen Rückenlehnen sowie Sitzbreiten und -höhen lieferbar. Die Identität wird letztendlich durch die Auswahl der Polsterung und der Beine bestimmt.

Francesc Rifé

“The soul of the collection lies in its forms”

“El alma de la colección reside en las formas”

“Die Seele der Kollektion lebt in den Formen”



A man whose life is devoted to design, Francesc Rifé (Sant Sadurní d'Anoia, Barcelona, 1969) brings his ideal of balance and simplicity to Dynamobel. With their clean, refined style, the new designs in the Be Wood and Fan collections mark the start of a close partnership: "The pieces reflect the visual language of the studio to perfection. They are sensible, timeless, versatile designs," Rifé tells us. They also herald the Navarrese company's new creative line, which aims to transform the office into a friendlier, more comfortable place. "Ever since my earliest days learning the trade, I've admired Dynamobel as one of the furniture companies most committed to R&D. That technical vision is now progressing towards a warmer, more plural world in which the products need to serve more than one function," the interior designer's words point towards Be Wood, a solid, oak-based collection, carried off in different shapes and heights. "Each piece is unique and able to withstand the test of time," he adds. "The soul of the collection lies in its forms. It has an ergonomic design which accommodates the user obligingly". Its smooth contours also make it the perfect range for the home.

Designed more for waiting rather than rest areas, Fan, a collection of sofas which speaks a formal, inflexible language, crowns the alliance. A design consisting of exact lines and a precise, geometric, architectural approach. "A piece with character," Francesc Rifé explains, "characterised by a subtle fold in the armrest area which enhances user comfort." Fan is available in three sizes and is particularly suitable for use in offices, restaurants and waiting rooms. Designs for a contemporary design experience.

En una vida dedicada al diseño Francesc Rifé (Sant Sadurní d'Anoia, Barcelona, 1969) extiende a Dynamobel su ideal de equilibrio y simplicidad. De estilo depurado y limpio los nuevos diseños de las colecciones Be Wood y Fan son el inicio de una estrecha colaboración: "Las piezas reflejan a la perfección el lenguaje visual del estudio. Son diseños sensatos, atemporales y polivalentes", describe Rifé. Son también la afirmación de la nueva línea creativa de la empresa navarra que busca transformar los espacios de oficina en lugares más próximos y confortables. "Desde mi etapa de formación admiraba a Dynamobel por ser una de las firmas de mobiliario que más fuerte apuesta por el I+D, esa visión técnica evoluciona ahora hacia un mundo más cálido y plural, en el que además los productos deben desempeñar más de una función", las palabras del interiorista y diseñador industrial conducen a Be Wood, una colección sólida, de estructura de roble, planteada en diferentes moldes y alturas. "Cada pieza es única y capaz de resistir el paso del tiempo", añade, "el alma de la colección reside en las formas, tiene un diseño ergonómico que te recoge amablemente", la suavidad de sus líneas la convierten en una serie también perfecta para el hogar.

La colaboración se completa con Fan, una colección de sofás que habla un lenguaje formal e inflexible, para entornos de espera más que de descanso. Un diseño de líneas exactas, enfoque geométrico, arquitectónico y preciso. "Una pieza con carácter", explica Francesc Rifé, "se caracteriza por un sutil pliegue en la zona del brazo que ayuda a la comodidad del sentado". Fan está disponible en tres tamaños y es particularmente apropiado para su uso en oficinas, restaurantes o salas de espera. Diseños para una experiencia de diseño contemporánea.

Der engagierte Designer Francesc Rifé (Sant Sadurní d'Anoia, Barcelona, 1969) teilt mit Dynamobel sein Ideal von Ausgewogenheit und Schlichtheit. Mit schlichtem und minimalistischem Stil sind die neuen Designs der Produktreihen Be Wood und Fan der Anfang einer engen Zusammenarbeit: „Die Teile spiegeln perfekt die visuelle Sprache des Studios wider. Es handelt sich um sinnvolle, zeitlose und polyvalente Designs», sagt Rifé. Sie sind ebenfalls die Bekräftigung der neuen kreativen Linie des navarrischen Unternehmens, dessen Ziel es ist, Büroräume benutzerfreundlicher und komfortabler zu gestalten. „Seit meinem Studium habe ich Dynamobel dafür bewundert, dass die Firma derartig stark auf I+D setzt. Diese technische Vision entwickelt sich heute in Richtung einer freundlicheren und pluralistischeren Atmosphäre, in der die Produkte außerdem mehr als nur eine Aufgabe erfüllen müssen.« Diese Aussage des Innenarchitekten und Industriedesigners führen zu Be Wood, einer soliden Kollektion, mit Struktur aus Eiche, konzipiert mit unterschiedlichen Formen und Höhen. „Jedes Möbelstück ist einzigartig und zeitlos. Das Wesen der Kollektion liegt in den Formen, sie hat ein ergonomisches Design, das einen entgegenkommend aufnimmt.« Dank der Subtilität ihrer Linien eignet sie sich ebenfalls perfekt für die Gestaltung von Wohnräumen. Die Zusammenarbeit wird mit an vervollständigt, einer Sofakollektion mit einer kompromisslosen Formensprache, eher für Wartebereiche als zum Ausruhen konzipiert. Ein Design mit exakten Linien, einem geometrischen, architektonischen und präzisen Konzept. „Ein Möbelstück mit Charakter zeichnet sich durch eine subtile Falte im Armlehnenbereich aus, die zum Komfort des Benutzers beiträgt,« erklärt Francesc Rifé. Fan ist in drei Größen erhältlich und besonders für Büros, Restaurants und Wartebereiche konzipiert. Kreationen, um zeitgenössisches Design zu erleben.





A smart design, capable of connecting with any space

Un diseño inteligente, capaz de conectar con cualquier espacio

Ein intelligentes Design, das in jeden Raum passt









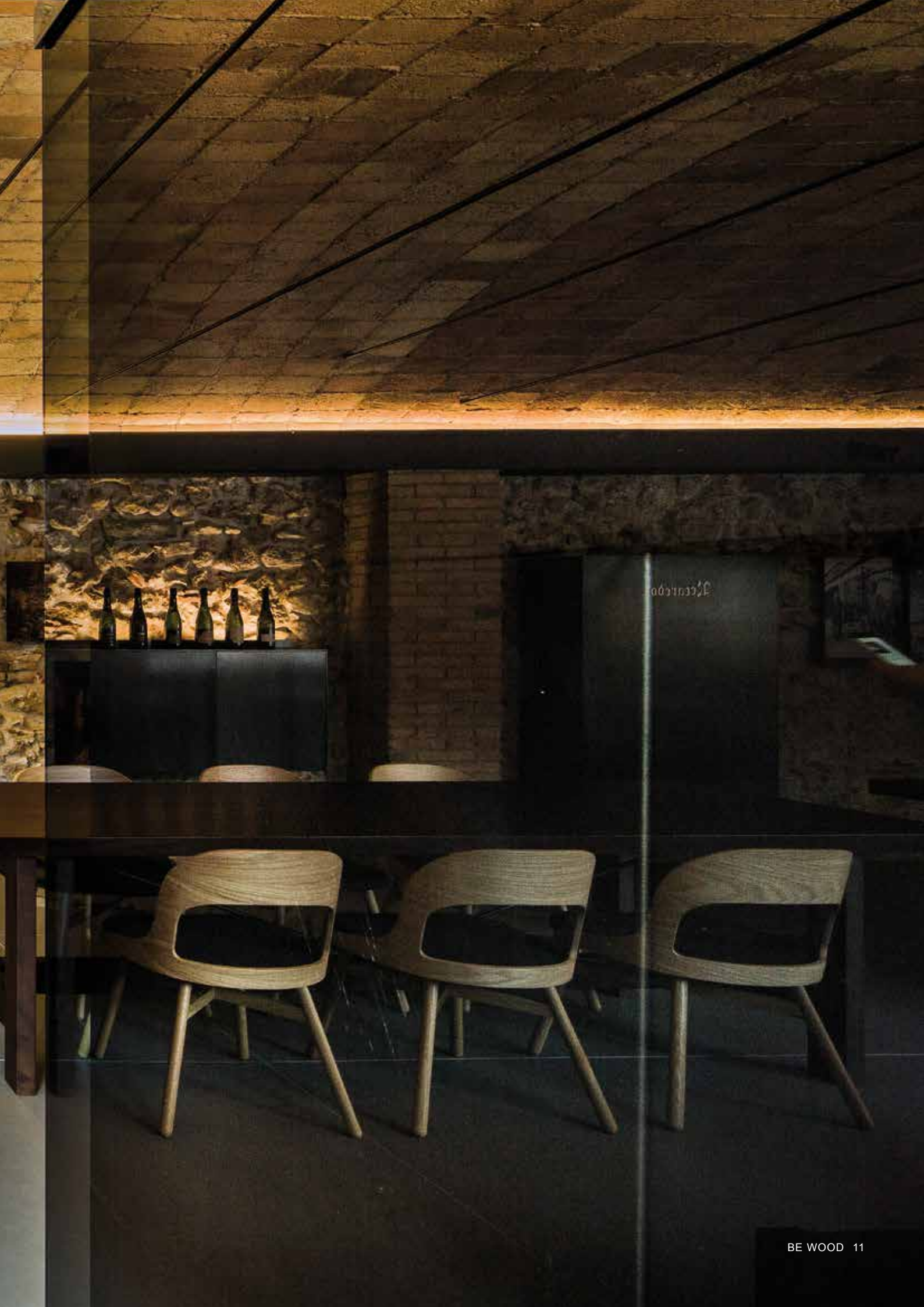

Harmony for the senses, serenity for the home
Armonía para los sentidos, serenidad para el hogar
Harmonie für die Sinne, Ausgeglichenheit für das Zuhause







Beyond the office
Más allá de la oficina
Mehr als nur fürs Büro











Fan

An architectural sofa
Un sofá arquitectónico
Ein architektonisches Sofa

To speak of Fan is to speak of geometry. The new range of sofas designed for Dynamobel by Francesc Rifé comes after thoroughly developing the concepts involved. Characterised by faceted cuts on the ends, Fan's technical nature contrasts with the gentle curves on the inside. A piece which evokes architecture, particularly suitable for use in offices, restaurants and waiting rooms.

The brand's answer to the future of contract furniture. Its legs, delicate extensions at each end which lift the seat just above floor level, also lend the Fan range identity.

A sleek, contemporary design on which the upholstery chosen defines the whole, selecting the same fabric all over or one type on the seat and backrest, and another on the structural shell. With a wooden frame made of reinforced Scots pine wood and metal legs with a black finish, the range comes in three sizes.

A design with a formal air which affords a better understanding of the space it occupies and confirms the company's new vision of the contract furniture sector.

Hablar de Fan es hablar de geometría. Tras un profundo desarrollo de conceptos nace la nueva gama de sofás diseñada por Francesc Rifé para Dynamobel. Caracterizada por líneas facetadas en los extremos, su carácter técnico contrasta con las amables curvas de su interior. Una pieza que evoca a arquitectura, particularmente adecuada para su uso en oficinas, restaurantes o salas de espera.

Es la respuesta de la marca al futuro del contract. Las patas, ligeras extensiones en sus extremos, también forman parte de su identidad y elevan al conjunto levemente por encima del suelo.

Una colección esbelta, contemporánea y cuyo tapizado puede definir el conjunto a través de un mismo tipo de tela o diferenciando los cojines del asiento y el respaldo de la parte envolvente. Con una estructura de madera de pino Flandes reforzada y patas metálicas acabadas en negro, la gama se presenta en tres tamaños.

Un diseño con acentos formales que permitirá una mejor comprensión del espacio y confirma la nueva mirada de la empresa hacia el sector del contract.

über Fan zu sprechen, bedeutet über Geometrie zu sprechen. Aus einer tief gehenden Konzeptentwicklung entsteht die neue, von Francesc Rifé entworfene Sofareihe. Gekennzeichnet durch facetierte Linien an den Enden, steht sein technischer Charakter mit den einladenden Kurven im Innenbereich in Kontrast. Ein Möbelstück, das Architektur evoziert, besonders für Büros, Restaurants oder Wartebereiche konzipiert.

Die Antwort der Marke auf die Kontrakt-Zukunft. Konzipiert als leichte Verlängerungen, bilden die Beine ebenfalls Teil seiner Identität und heben das Sofa ein wenig vom Boden ab.

Eine schlanke, zeitgenössische Kollektion, deren Bezüge die Möbelgruppe entweder durch gleiche Stoffe oder aber mit Sitz- und Rückenlehnenpolstern in abgehobenen Stoffen definieren. Mit einer verstärkten Struktur aus Kieferholz aus Flandern und schwarzen Metallbeinen ist die Produktreihe in drei Größen lieferbar.

Ein Design mit formalem Akzent, das ein besseres Verständnis des Raums ermöglicht und einen neuen Blick der Firma auf das Kontraktgeschäft bestätigt.





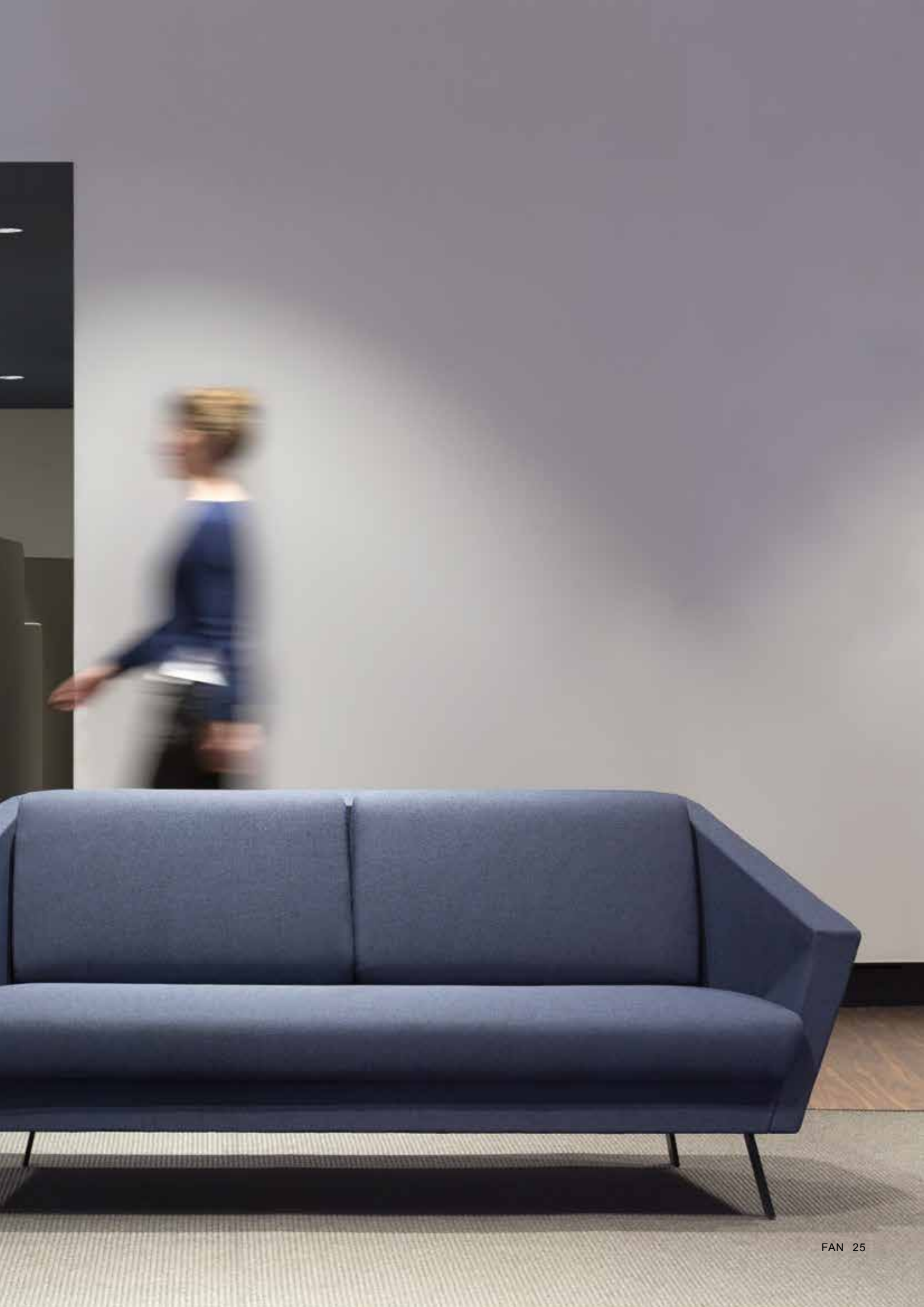





Auxiliary tables

A question of balance

Cuestión de equilibrio

Eine Frage der Ausgewogenheit

With their timeless, minimalist design, the Be Wood auxiliary tables allude to the same organic forms as the seating collection. Francesc Rifé's contours join up with Dynamobel's experience and expertise in three versatile, intentionally simple designs. Seeking the purest of forms, the attention focuses on the legs and the design is completed with a round surface. A design which deliberately avoids the superfluous.

The Petal version is a dynamic table which plays with the movement of one, two or three surfaces, the combinations of which can be customised. Intended to stand alone or with chairs and sofas, its petals suggest the natural forms of a flower.

Drum works as a design which connects round surfaces. The choice of finishes highlights the different top surfaces and heights. A refined structure unifies the whole and brings a unique touch to any room. Available in a variety of finishes, the aim of the collection is to create timeless, balanced designs which will last aesthetically and physically over time.

Siguiendo un enfoque atemporal y minimalista, las mesas auxiliares Be Wood hacen referencia a las mismas formas orgánicas que la colección de sillería. El trazo de Francesc Rifé se une a la herencia y saber hacer de Dynamobel en tres diseños versátiles y deliberadamente simples. En su expresión más pura la atención se centra en las patas y se completa con una superficie redonda. Un diseño consciente que evita lo superfluo. La versión Petal es una propuesta dinámica que juega con el movimiento de una, dos o tres superficies, cuyas combinaciones pueden ser personalizadas. Destinada a funcionar en solitario o junto a sillas y sofás, sus pétalos hacen referencia a las formas naturales de una flor.

Drum funciona como un diseño de conexión entre superficies redondas, la selección de acabados pondrá en relieve los diferentes sobres y alturas. Una sutil estructura unificará el conjunto y aportará un carácter único a cualquier sala.

Disponibles en una gran variedad de acabados, el objetivo de la colección es crear diseños atemporales y equilibrados que perduren estética y físicamente en el tiempo.

Durch ihr zeitloses und minimalistisches Konzept beziehen sich die Beistelltische auf die gleichen organischen Formen wie die Stuhlkollektion. Die Linie von Francesc Rifé vereint sich mit dem Erbe und dem Know-how von Dynamobel in drei vielseitigen und absichtlich einfachen Designs. In ihrem reinsten Ausdruck konzentriert sich die Aufmerksamkeit auf die Beine und wird durch eine runde Oberfläche vervollständigt. Ein bewusstes Design, das Überflüssiges vermeidet.

Die Version Blütenblatt ist eine dynamische Option, die mit der Bewegung von einer, zwei oder drei Oberflächen spielt, deren Kombinationen personalisiert werden können. Alleinstehend oder zusammen mit Stühlen und Sofas spielen die Blütenblätter auf die natürlichen Formen einer Blume an.

Drum stellt ein Verbindungsdesign zwischen runden Oberflächen dar. Die Auswahl der Ausführungen betont die verschiedenen Tischoberflächen und Höhen. Eine subtile Struktur vereinigt die Gruppe und verleiht jedem Raum ein einzigartiges Ambiente.

Das Ziel der Kollektion besteht darin, zeitlose und ausgewogene Designs zu schaffen, die sowohl ästhetisch als auch physisch langlebig sind. In vielen verschiedenen Ausführungen lieferbar.







BE WOOD 50

Operator chair
Silla operativa
Arbeitsstuhl

Fabric backrest
with arms

Respaldo tapizado
con brazos

Gepolsterte Rückenlehne
mit Armlehnen



L673 X D629 X H862/982

Features: Height-adjustable lumbar support, backrest lock, self-adjusting backrest tilt tension, height-adjustable seat, height-adjustable armrests.

Prestaciones: Ajuste en altura de la zona lumbar, bloqueo del respaldo, tensión del respaldo auto-ajustable, ajuste altura del asiento, ajuste altura del reposabrazos.

Merkmale: Höhenverstellbar im Lumbarebereich, Rückenlehnenblockierung, selbstjustierende Rückenlehnen Spannung, sitz-Höhenverstellung, armlehnen-Höheneinstellung.

4 wooden legs

4 patas de madera
4 Holzbeine

4 metal legs

4 patas metálicas
4 Metallbeine

Cantilever base

Patín
Freischwinger

4 star base

Giratoria base 4 radios
Drehstuhl mit 4-armigem
Fußkreuz

Fabric backrest
with arms

Respaldo tapizado
con brazos

Gepolsterte Rückenlehne
mit Armlehnen

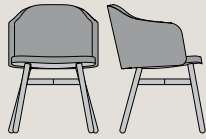

L525 X D575 X H750

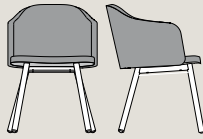

L525 X D575 X H750

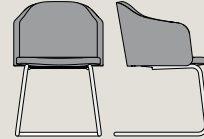

L525 X D555 X H750

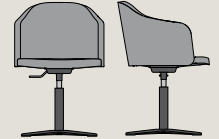

L525 X D560 X H780/880

Wooden backrest
with arms

Respaldo madera
con brazos

Rückenlehne aus Holz
mit Armlehnen

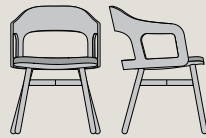

L525 X D575 X H750

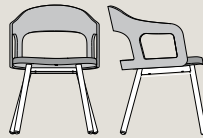

L525 X D575 X H750

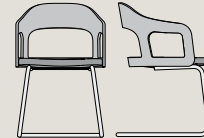

L525 X D555 X H750



L525 X D560 X H780/880

Fabric backrest
without arms

Respaldo tapizado
sin brazos

Gepolsterte Rückenlehne
ohne Armlehnen

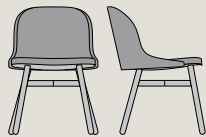

L525 X D575 X H750

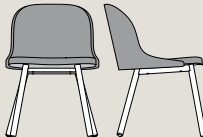

L525 X D575 X H750

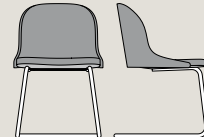

L525 X D555 X H750



L525 X D560 X H780/880

Wooden backrest
without arms

Respaldo madera
sin brazos

Rückenlehne aus Holz
ohne Armlehnen

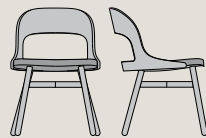

L525 X D575 X H750

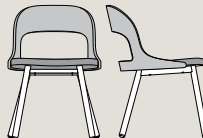

L525 X D575 X H750

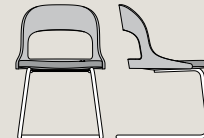

L525 X D555 X H750



L525 X D560 X H780/880

Fabric backrest
with jutting arms

Respaldo tapizado
con brazos en voladizo

Gepolsterte Rückenlehne
geschwungenen Armlehnen

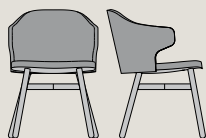

L525 X D575 X H750

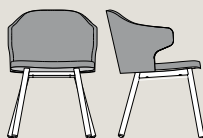

L525 X D575 X H750

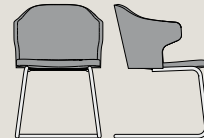

L525 X D555 X H750

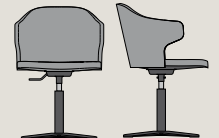

L525 X D560 X H780/880

BE WOOD 40

BE WOOD 70

5 star base

Giratoria base 5 radios
Drehstuhl mit 5-armigem
Fußkreuz



L525 X D610 X H780/880

4 wooden legs

4 patas de madera
4 Holzbeine



L461 X D462 X H876

Sled base

Trineo
Kufengestell



L450 X D483 X H873

4 wooden legs

4 patas madera
4 Holzbeine

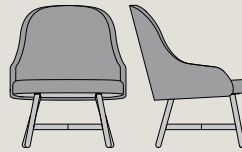

L696 X D714 X H841

4 metal legs

4 patas metálicas
4 Metallbeine

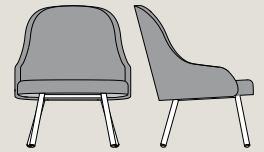

L696 X D714 X H844



L525 X D610 X H780/880



L525 X D610 X H780/880



L525 X D610 X H780/880



L525 X D610 X H780/880

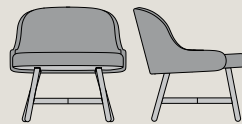

L696 X D659 X H633

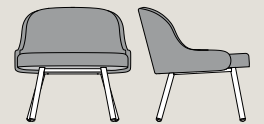

L696 X D659 X H633

L
Total width
Anchura total
Gesamtbreite

D
Total depth
Profundidad total
Gesamttiefe

H
Total height
Altura total
Gesamthöhe

BE WOOD FINISHES. ACABADOS BE WOOD

OAK. ROBLE



Finish for backrest and base. Oak finish only available on 4-leg base.
Acabado para respaldo y base. El acabado Roble sólo disponible para base de cuatro patas.
Finish für Rückenlehne und Fuß. Ausführung in Eiche nur mit 4 Beinen lieferbar.

RE Oak
Roble

POLYAMIDE. POLIAMIDA



Finish for 5-spoke swivel base.
Acabado para base giratoria de 5 radios.
Finish für 5-armiges Fußkreuz.

NE Black
Negro

PLAIN COLOR. COLOR PLANO



AK Electric Blue
Azul eléctrico

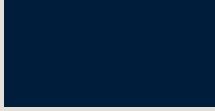

AJ Navy blue
Azul marino



AG Storm Blue
Azul roto



AF Ice Blue
Azul gélido

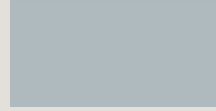

AE Grey Blue
Azul grisáceo

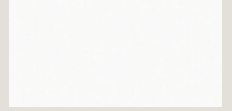

BA White
Blanco



VV Spring green
Verde primavera



GV Greenish grey
Gris verdoso



VT Laurel green
Verde laurel



VG Khaki green
Verde caqui



VP Pistachio green
Verde pistacho

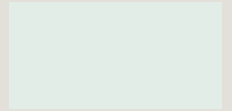

VA Sea blue
Aquamarina



HD Mustard yellow
Amarillo mostaza



BG Chocolate
Chocolate

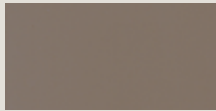

BT Mocha brown
Tostado



BE Smoke
Humo

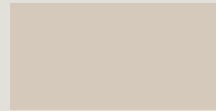

BD Stone
Piedra

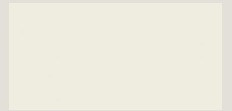

BC Cream white
Blanco crema



CV Bright red
Rojo vivo



CG Burgundy
Granate



RO Red
Rojo



CD Orange
Naranja

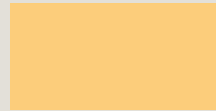

CC Vanilla
Vainilla

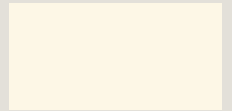

CB Faded white
Blanco roto



NE Black
Negro



GF Deep grey
Gris profundo



GA Anthracite grey
Gris antracita



GE Mouse grey
Gris ratón

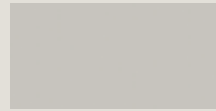

GC Light grey
Gris claro

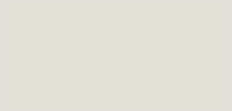

GD Off white
Blanco sucio

METALLIE EPOXY. PINTURA METALIZADA



GP Platinum grey
Gris platino



GG Graphite grey
Gris grafito

POLISHED. PULIDO

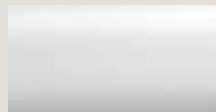

CR Polished
Pulido

Only available on swivel base.
Sólo está disponible para la base giratoria.
Nur für Drehgestell lieferbar.

There is a 3% surcharge on the finishes with codes in red.

Acabados con código rojo tienen un incremento respecto a la tarifa del 3%.

Für die mit rotem Code gekennzeichneten Ausführungen gilt ein Aufschlag von 3 %.

UPHOLSTERY. TAPIZADO

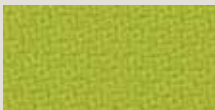

GS33



GS35



GS36



GS41



GS42



GS47



GS46



GS12



GS14



GS57



GS56



GS61



GS69



GS10



GS16



GS20

See more collections in our catalogue.

Consultar más colecciones es nuestro catálogo.

Weitere Kollektionen finden Sie in unserem Katalog.

FAN

1-seater
Sofa 1 plaza
Sofa 1-Sitzer

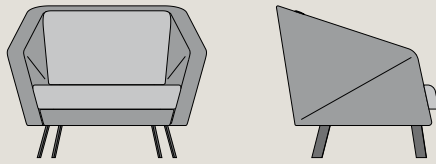

L1000 X D830 X H750

2-seater
Sofa 2 plazas
Sofa 2-Sitzer

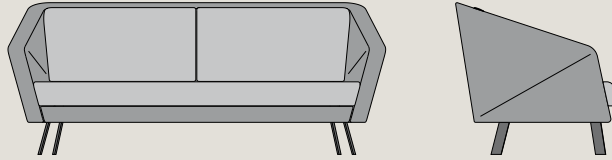

L1800 X D830 X H750

3-seater
Sofa 3 plazas
Sofa 3-Sitzer

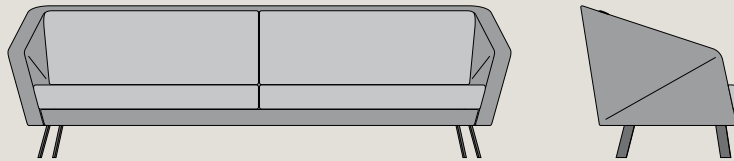

L2400 X D830 X H750

L
Total width
Anchura total
Gesamtbreite

D
Total depth
Profundidad total
Gesamttiefe

H
Total height
Altura total
Gesamthöhe

FAN FINISHES. ACABADOS FAN

PLAIN COLOR. COLOR PLANO



NE Black
Negro

UPHOLSTERY. TAPIZADO



GM33

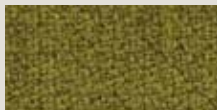

GM35



GM36



GM41



GM42



GM47



GM46



GM12



GM14



GM57



GM56



GM61



GM69



GM10



GM16

See more collections in our catalogue.
Consultar más colecciones en nuestro catálogo.
Weitere Kollektionen finden Sie in unserem Katalog.

AUXILIARY TABLES. MESAS AUXILIARES

Round table slanted metal legs

Mesa redonda pata metálica inclinada
Runder Tisch mit gewinkeltem Metallbein

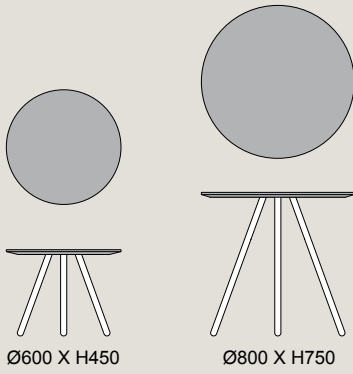

Ø600 X H450

Ø800 X H750

Petal table straight metal legs (petal)

Mesa pétalo pata metálica recta (petal)
Blütenblattförmiger Tisch mit geradem Metallbein (petal)

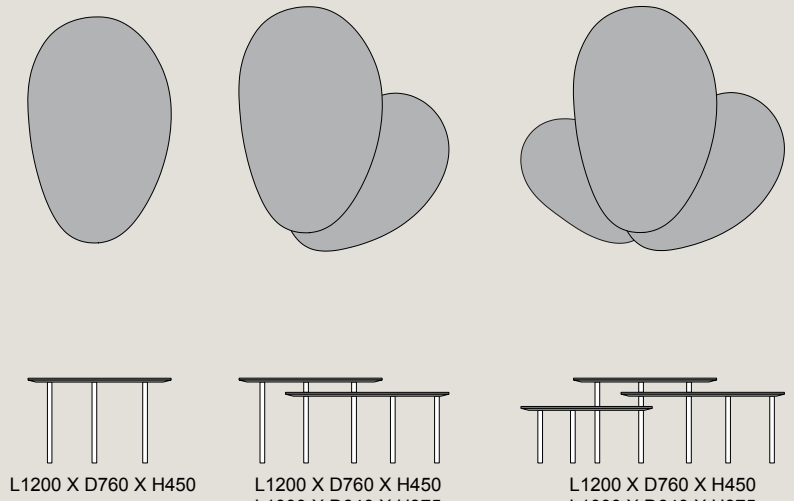

L1200 X D760 X H450

L1200 X D760 X H450
L1000 X D640 X H375

L1200 X D760 X H450
L1000 X D640 X H375
L800 X D520 X H300

Round table slanted wooden legs

Mesa redonda pata madera inclinada
Runder Tisch mit gewinkeltem Holzbein

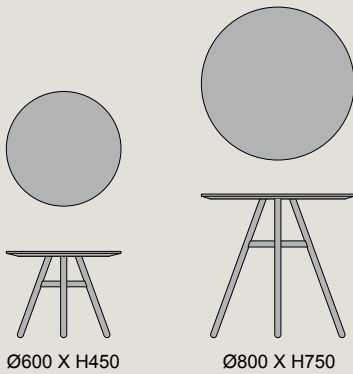

Ø600 X H450

Ø800 X H750

Round table straight metal legs (drum)

Mesa redonda pata metálica recta (drum)
Runder Tisch mit geradem Metallbein (drum)

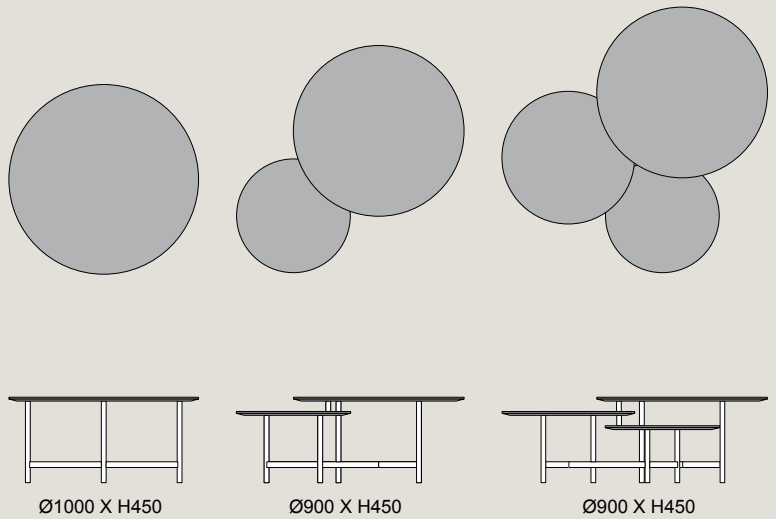

Ø1000 X H450

Ø900 X H450
Ø600 X H375

Ø900 X H450
Ø700 X H375
Ø600 X H300

Detail of table edge

Detalle canto de mesa
Einzelheit Tischkante

















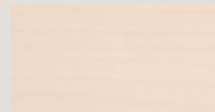



L
Total width
Anchura total
Gesamtbreite

D
Total depth
Profundidad total
Gesamttiefe

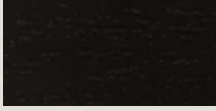

H
Total height
Altura total
Gesamthöhe

TABLE FINISHES. ACABADOS MESAS

WOOD VENEER. MADERA

					
NB White walnut Nogal blanco	NG Grey walnut Nogal gris	NN Walnut Nogal	NM Honey Walnut Nogal miel	AB White maple Arce blanco	AN Natural maple Arce natural
					
RB White oak Roble blanco	RG Grey oak Roble gris	RS Black oak Roble negro	RC Cream oak Roble crema	RD Honey oak Roble miel	RP Brown oak Roble marrón
					
MB White straight Mallada blanca	MG Grey straight Mallada gris	MS Black straight Mallada negra	MC Cream straight Mallada crema	MD Honey straight Mallada miel	MP Brown straight Mallada marrón

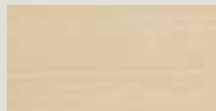
HPL. ESTRATIFICADO

		
AU Birch Abedul	RM Oak Roble	AA Acacia Acacia

OAK. ROBLE

	<p>Oak finish only available on 4-leg base. El acabado roble sólo disponible para base de cuatro patas. Ausführung in Eiche nur mit 4 Beinen lieferbar.</p>
RE Roble Oak	

PLAIN COLOR (PAINTS AND LACQUERS). COLOR PLANO (PINTURAS Y LACAS)

					
AK Electric Blue Azul eléctrico	AJ Navy blue Azul marino	AG Storm Blue Azul roto	AF Ice Blue Azul gélido	AE Grey Blue Azul grisáceo	BA White Blanco
					
VV Spring green Verde primavera	GV Greenish grey Gris verdoso	VT Laurel green Verde laurel	VG Khaki green Verde caqui	VP Pistachio green Verde pistacho	VA Sea blue Aquamarina
					
HD Mustard yellow Amarillo mostaza	BG Chocolate Chocolate	BT Mocha brown Tostado	BE Smoke Humo	BD Stone Piedra	BC Cream white Blanco crema
					
CV Bright red Rojo vivo	CG Burgundy Granate	RO Red Rojo	CD Orange Naranja	CC Vanilla Vainilla	CB Faded white Blanco roto
					
NE Black Negro	GF Deep grey Gris profundo	GA Anthracite grey Gris antracita	GE Mouse grey Gris ratón	GC Light grey Gris claro	GD Off white Blanco sucio

METALLIE EPOXY. PINTURA METALIZADA

	
GP Platinum grey Gris platino	GG Graphite grey Gris grafito

There is a 3% surcharge on the finishes with codes in red.
Acabados con código rojo tienen un incremento respecto a la tarifa del 3%.
Für die mit rotem Code gekennzeichneten Ausführungen gilt ein Aufschlag von 3%

Dynamobel S.A.

CENTRAL INBOX, SPAIN

Ctra. Madrid Km 24
31350 Peralta
Navarra, Spain
T +34 948 750 000
F +34 948 750 750
info@dynamobel.com

CENTRAL BOX, SPAIN

Ctra. de Guipúzcoa Km 7,5
Apdo. 1074 31080 Pamplona
Navarra, Spain
T +34 948 303 171
F +34 948 302 581
info@dynamobel.com

DESIGN FRANCESC RIFÉ STUDIO
PHOTO STYLING FRANCESC RIFÉ STUDIO
PHOTOGRAPHY DAVID ZARZOSO
APPRECIATIONS HABITUAL RESTAURANTE, RICARD
CAMARENA, CAIXA BANK, RECAREDO

KJM/CAT/109/11

© DYNAMOBEL. ALL RIGHTS RESERVED.
REPRODUCTION OF THE WHOLE OR ANY PART
OF THE CONTENTS IS PROHIBITED.

We are breaking out of the rigid structure through which many companies in the sector impose standard solutions without questioning the constraints these place on good ideas.

Our aim is to venture beyond, stay one step ahead, because we believe that good ideas deserve more than a simple, all-embracing solution.

We work to understand designers and look into ways of solving their work, providing a suitable balance between customisation and industrialisation. Good ideas do not compromise form or function. We will defend that come what may.

Nos salimos de la estructura rígida de muchas empresas del sector en el que se imponen soluciones estándar sin cuestionarse las limitaciones que éstas imponen en las buenas ideas.

Nuestro propósito es ir más allá, un paso por delante, porque creemos que las buenas ideas merecen más que una solución masiva.

Trabajamos por entender a los creadores y explorar formas de resolver sus obras, que ofrezcan un adecuado equilibrio entre personalización e industrialización. Las buenas ideas no comprometen forma ni función. Defenderemos esto ante todo.

Wir haben uns von den starren Strukturen gelöst, in denen viele Unternehmen des Sektors verharren, indem sie Standardlösungen bieten, ohne sich dabei die Frage zu stellen, in welchem Maße diese die Umsetzung guter Ideen einschränken.

Wir haben es uns zum Ziel gesetzt, weiter zu denken und immer einen Schritt voraus zu sein, denn wir sind überzeugt, dass eine gute Idee mehr verdient als einfach nur eine vorgefertigte Lösung.

Wir bemühen uns, die Menschen, die Ideen entwickeln, zu verstehen, und versuchen, Mittel und Wege zu finden, um diese Ideen zu verwirklichen, ohne dabei jedoch ein angemessenes Gleichgewicht zwischen Individualität und Standardisierung aus dem Auge zu verlieren. Gute Ideen beeinträchtigen weder Form noch Funktion. Diesen Standpunkt vertreten wir mit allem Nachdruck.

